

COIL WINDING



MODEL 43

MULTI-REEL WIRE RACK

Prevents tangled, broken, stretched or damaged wire.

Design

The Multi-Reel wire rack offers you a convenient method of storing reels of wire, plus an efficient material handling system for feeding and tensioning wire from multiple reels.

The Way it Works

Each stored wire size is ready for immediate use on every winding job, without wasting any time in handling reels or looking for the desired wire size.

Wires are guided through eyelets and around sheaves to the tension device and are immediately ready for use.

Construction

Frame members are welded for structural strength and long term durability.

Model 43 can be used with many types of tensioning devices.



Model 43 illustrated with optional Model 4965 Permanent Magnet Tensioning Device



Model 4965 Permanent Magnet Tensioning Device

Capacity	4 Reels
Weight Capacity	160 Lbs.
Maximum Wire Size	No. 14 Wire
Dimensions	18"W x 30"L x 46"H
Net Weight	175 Lbs.
Gross Weight	200 Lbs.

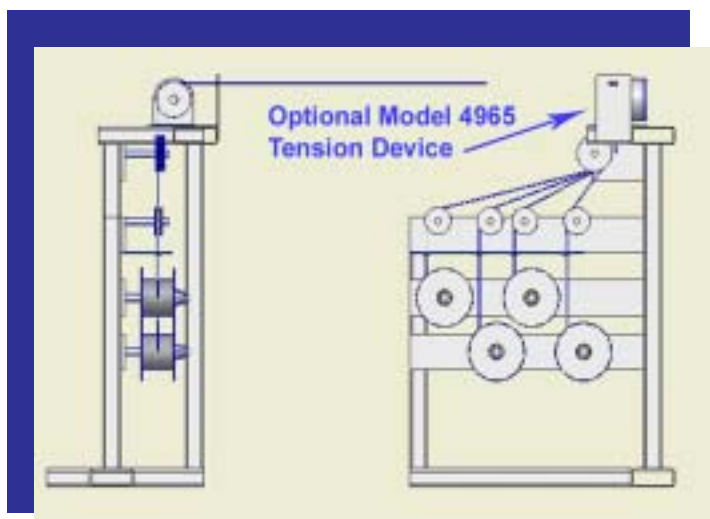

ace Since 1959
ACE EQUIPMENT COMPANY
 4725 MANUFACTURING ROAD
 CLEVELAND, OHIO 44135
WWW.ARMATURECOIL.COM
 800-255-1241 • 216-267-6366 • FAX 216-267-4361